



Estate Swing brand gate openers are a Sequoia Brands, Inc. product.
Please visit www.estateswing.com for manual updates and other product information.
This gate opener is low voltage and bolt on specifically designed for homeowner installation.

—WARNING—

Read all instructions before beginning installation or use of this gate opener. This operator exerts a high level of force. Exercise caution at all times and stay clear of the system during operation.

E-S Allegiant Series

Single Swing and Dual Swing Gate Opener

Do-It-Yourself Installation and Operation Manual

The Estate Swing is only to be used for vehicular swing gates in a Class I setting.

Class I: A vehicular gate opener (or system) intended for use in a home of one-to-four single family dwelling, or a garage or parking area associated therewith.
The Estate Swing automated system was designed and built for controlling vehicle access. Do not use for any other purpose.

Max gate leaf size:



IMPORTANT INFO ABOUT GATE

- The gate and post must be suitable for being automated. Check that the structure is sufficiently strong and rigid, and its dimensions and weights conform to those indicated above.
- Make sure the gates move smoothly without any irregular friction during entire travel.
- Make sure the hinges are in good condition. Ball bearing hinges are necessary for automation.
- Make sure the gate is plumb and level.
- The gate post must be secured in the ground with concrete. This will prevent alteration of alignments and leveling during installation and during cycles.
- Gate must not have more than 50% coverage preventing wind from passing through gate.

The system displayed below is a recommended standard system. Other approved accessories can be installed. Photo sensors and a flashing light indicating gate movement is recommended for safety purposes.

1,2 Estate Swing Operator • 3 Photocells (not included) • 4 Control box 6 Keypad (not included) • 7 Receiver extension (not included) • 8 12Vdc flashing lamp (not included) • 9 Positive stop (not included) • 10 Charging Control

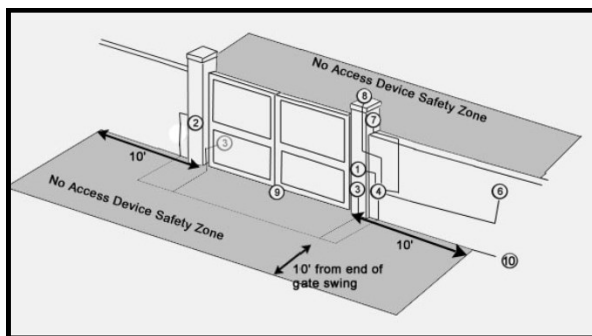

Notes:

- 1) When laying electrical cables, use appropriate rigid and/or flexible tube
- 2) Do not run any wires in the same conduit as 110 AC power that may be in the area. This will cause danger of electrocution.

Important: Do not turn the shaft of the operator arm until the post and gate brackets are fully installed.



Emergency Release

Emergency Release Procedure:

- 1) Remove the pin as seen to the right.
- 2) Swing motor off of the gate bracket.
- 3) Swing gate and opener out of the way of access.



Important Notes About Product

- The gate opener is device of convenience for opening and closing the gate, not a security device. Estate Swing is not responsible for the security of property on which the gate opener is installed. Additional accessories such as gate locks, videocoms, and other devices are available to enhance security, are sold separately, and may or may not be available under the Estate Swing brand.
- This product is a Do-It-Yourself product. It is intended to be installed, repaired and maintained by a purchasing home owner. Any and all paid labor involved with this product is the sole responsibility of the individual that hired the labor.
- Properties that contain live stock, children and pets should not allow them direct access to the gate safety zone. Additionally we suggest the following precautions: Install safety edges and photo eyes, do not use any devices that open the gate automatically for vehicles such as loops or exit sensors, install an automatic gate lock and positive stops, do not use auto-reclose or remote access devices - only trigger the gate to move while it is in direct site.

Parts

Single Gate Opener Kit with Transformer Charging

Gate Bracket
 Gate Bracket Hardware
 2) 3/8" x 2" Carriage Bolt, Lock washer, Washer, Nut
 1) 1/4" x 2" Hex Bolt, Lock Washer, Washer, Nut
 1) Clevis pin
 1) Cotter Pin]



Warning Sign

Setback Templates



Operator Arm

2 Post "L" Shape brackets
 Post "Boomerang" bracket
 Post Bracket Assembly Hardware:
 1) 3/8" x 1 1/2" Hex Bolt, Lock washer, Washer, Nut
 1) 5/16" x 1 1/2" Hex Bolt, Lock Washer, Washer, Nut]

Control box with control board



Remote transmitter



Battery lift for larger batteries



Battery Harness wire with two loose ends for you to attach to battery connectors (not included)



Transformer with spade connectors for wire



Charge controller

Additional items for Dual Gate Opener Kit



Secondary motor wire

Secondary wire junction and box

Alternate items for Solar Kits



No transformer



No charge controller unless 20 Watt panel or above



Solar panel with mounting post, hardware and wire

Needed Tools and Parts Checklist

Check off the items as you account for them and if you need to purchase an item add it to the shopping list side on the right

- ◇ Power Drill with 3/8, 1/4 and 5/16 inch bits
- ◇ Crescent Wrench
- ◇ Flat Head Screwdriver
- ◇ Hacksaw/Sawzall
- ◇ Phillips Head Screwdriver
- ◇ Small Flathead Screwdriver
- ◇ C-Ring Pliers
- ◇ Tape Measure
- ◇ Level
- ◇ Wire Strippers
- ◇ C-clamps
- ◇ 3/8", 1/4", 5/16" Drill Bits
- ◇ Multi-meter (troubleshooting)
- ◇ Digital camera / cell phone camera (troubleshooting)

Shopping List

Group Size 24 Deep Cycle Marine battery and battery terminal wire connectors (2 sets of connectors).

Available at auto parts stores, battery stores, and some hardware stores. Max dimensions 9H x 11.5Wx7D

Different batteries have different lugs or spades, purchase connectors that crimp to wire for the battery you are buying.



Positive post, bracket or door stop.

This would differ depending on your gate. It is an object for the gate to close against. This is recommended for a tight closed position.



16 gauge, 2 conductor stranded direct burial low voltage wire

Needed for wired accessories, the transformer to the control box, the solar panel to the control box.

4 - 3/8" Carriage Bolts, Lock Washers and Nuts

This is for attaching your brackets to your post. If you have a block column purchase 3/8" anchors instead. Purchase the bolts at the length needed to pass through your post.

Water tight connectors / Wire strain reliefs

When running wire into your control box, the holes the wires pass through should be secured to prevent water / elements of nature from entering. The number of strain reliefs would be determined by the number of wires entering the box. Box has 2) 1-1/4" and 4) 7/8" knockouts.



4 - #10 Self-drilling Metal Screws

Or other appropriate hardware. This is for attaching the control box to the post or fence.



Outdoor Dome Plug Cover

Or electrical box if you are using a transformer to charge the battery and the receptacle is outdoors. Receptacles and transformers must always be kept dry.



Determine Pull or Push to Open Operation

The next steps will be split with pull to open on left and push to open on right

PULL TO OPEN: This means the gate operator is mounted on the inside of the property and pulls your gate in towards the property.

The majority of installations are pull to open.

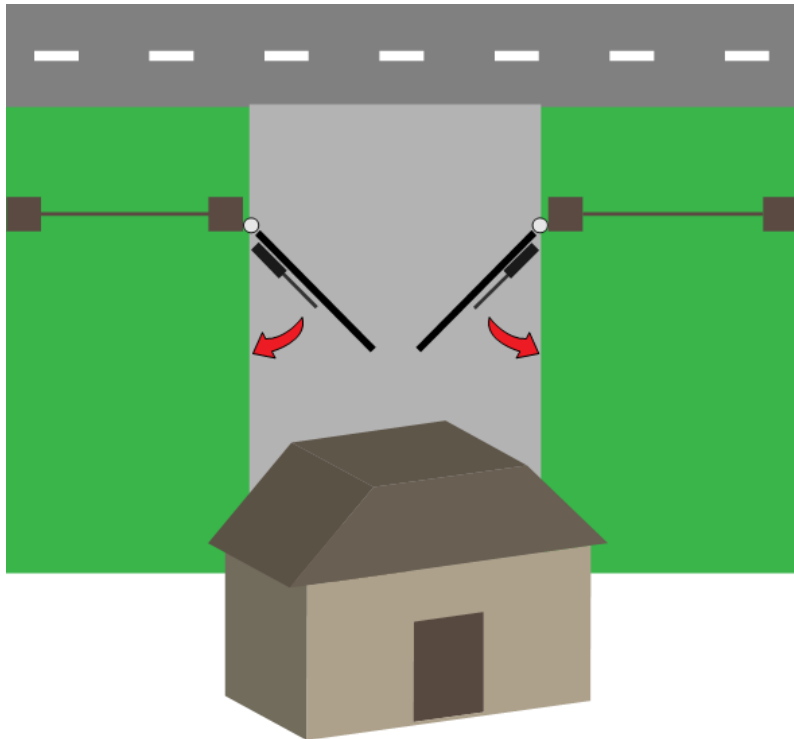

PUSH TO OPEN: This operation is commonly used if your driveway slopes up after the gate, preventing it from swinging in. This installation can also be used if you have columns too large to accommodate pull to open setbacks.

This means the gate operator is mounted on the inside of the property and pushes your gate out away from the property.

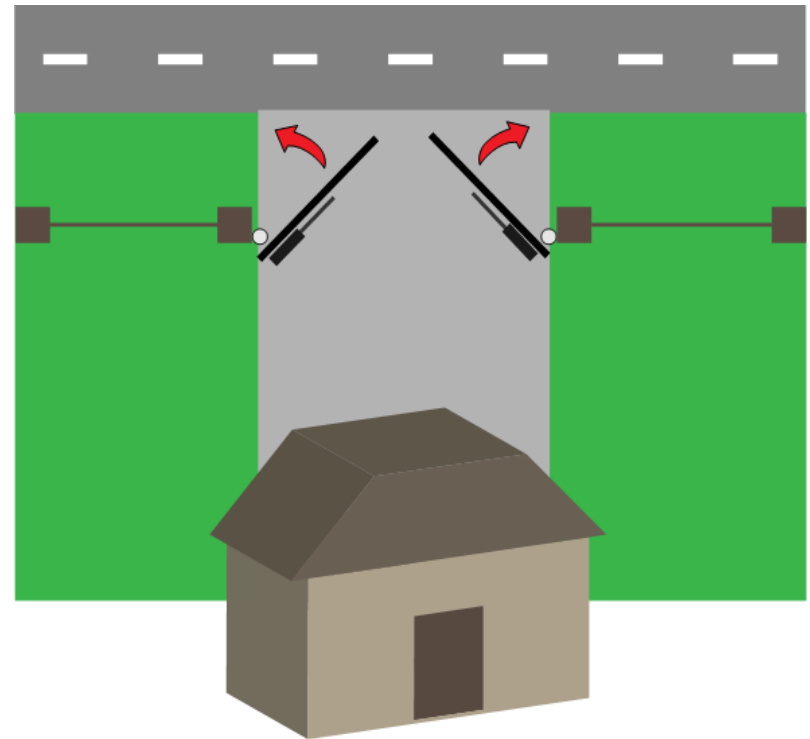

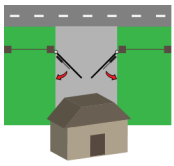

Determine the setback needed

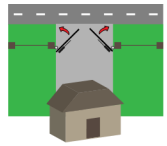

Below are 2 common examples of Pull to Open setback mountings. These are not the only options for mounting.

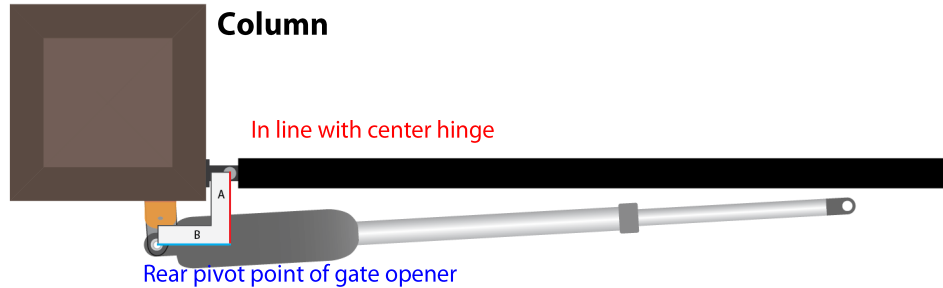
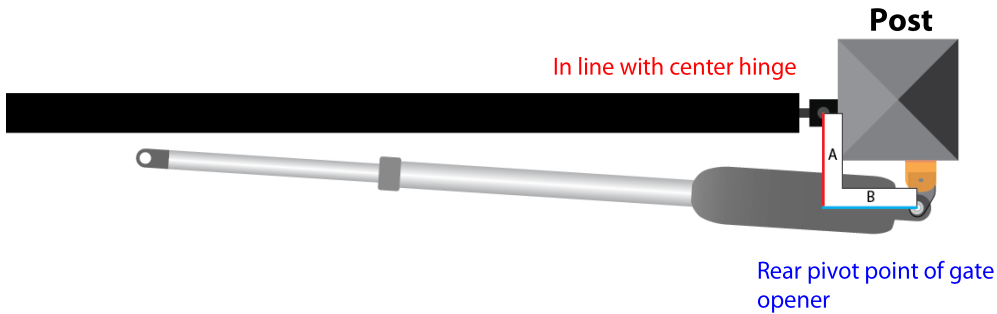

Use one of the rows to the right

A	B	Degree Open
5.5"	6.5"	110°
6.75"	6.75"	100°
7.5"	7.5"	90°

Below are 2 common examples of Push to Open setback mountings. These are not the only options for mounting.

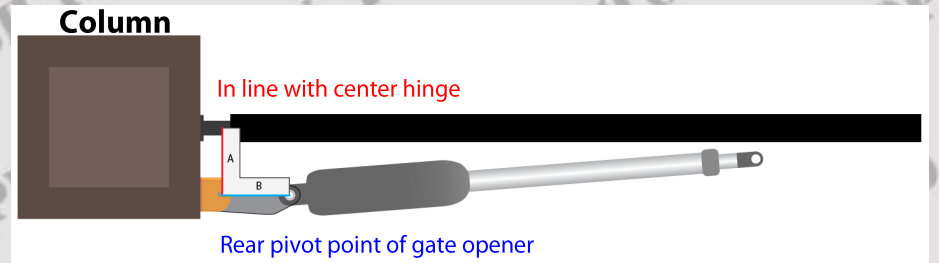
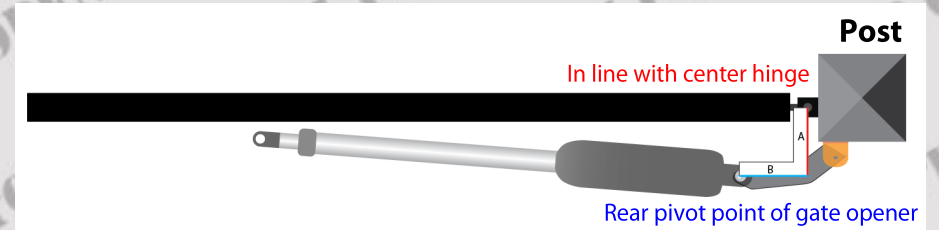

Use one of the rows to the right

A	B	Degree Open
5.5"	6.5"	110°
6.75"	6.75"	100°
7.5"	7.5"	90°

There are 5 factors to keep in mind when finding the setback mounting:

- 1) The (A) measurement is perpendicular from the gate in the CLOSED position.
- 2) If Pull to open setback is not achievable, typically on columns. Re-positioning of the hinges or Push-To-Open operation may be required to achieve clearance.
- 3) The brackets do not and must not move after installation.
- 4) The "L" shape brackets can be mounted anywhere on the post or column. The only location of importance is the boomerang bracket that the gate opener attaches to matches the setback on this page.
- 5) Use the setback for the degree you are trying to open. Do not use the 110 degree setback to only open 90.

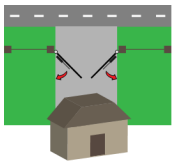

Installation

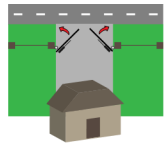

1. Place one corner of the setback template on the center of the hinge of the gate. Direct it so it is perpendicular from the closed gate. Use the correct setback template for your degree of opening.

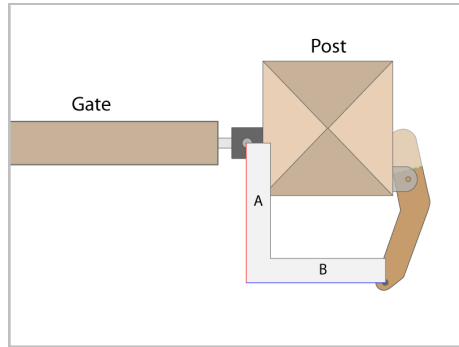

1. Place one corner of the setback template on the center of the hinge of the gate. Direct it so it is perpendicular from the closed gate. Use the correct setback template for your degree of opening.

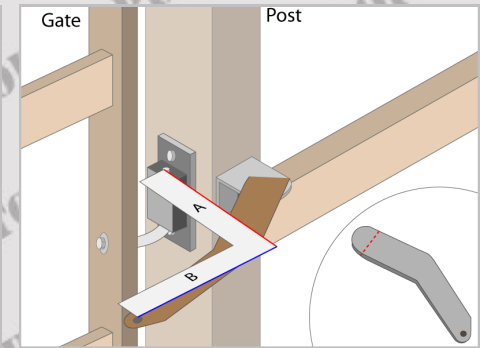
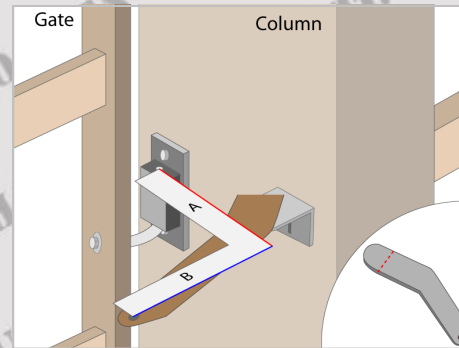
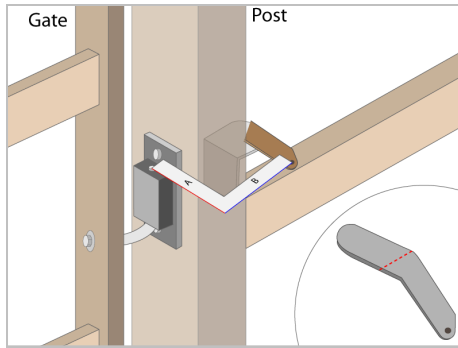
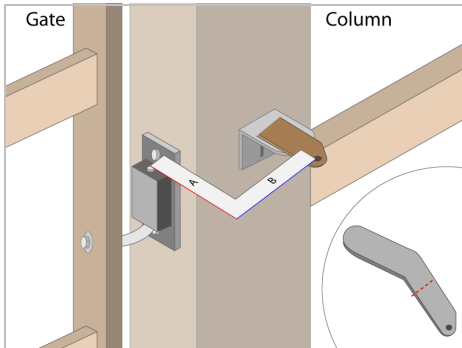
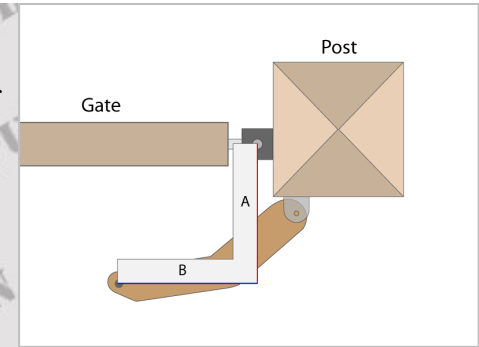

2. Place the boomerang template on the other corner of the setback template. Pivot the boomerang bracket template to the post so it sits on an L shape bracket that you hold on the post or column. Mark the boomerang bracket template for trimming. Trim the boomerang bracket to match the template.

2. Place the boomerang template on the other corner of the setback template. Pivot the boomerang bracket template to the post so it sits on an L shape bracket that you hold on the post or column. Mark the boomerang bracket template for trimming. Trim the boomerang bracket to match the template.

3. Find the height for the post bracket assembly. Place a level on the bottom of a suitable cross member for the mounting the gate opener (minimum 1 foot off ground level) to the gate. Mark the post with a line at this level.

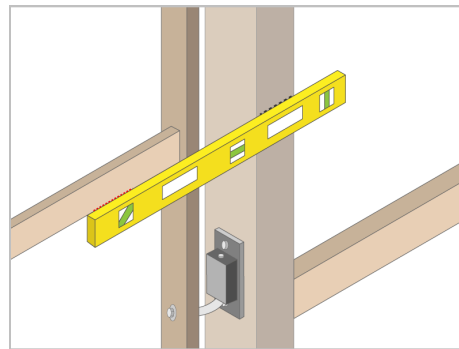

3. Find the height for the post bracket assembly. Place a level on the bottom of a suitable cross member for the mounting the gate opener (minimum 1 foot off ground level) to the gate. Mark the post with a line at this level.

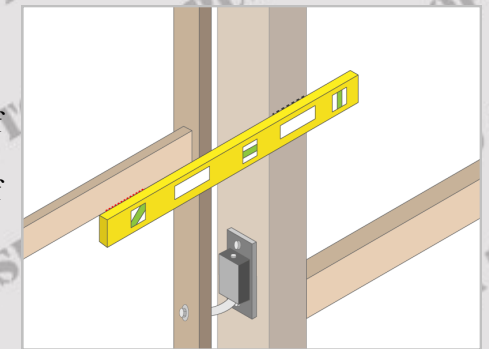

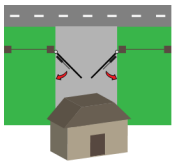

4. Place one of the L shape brackets with the top lined up with the line drawn on the post in step 3. The side of post the bracket will be on was determined in step 2 when lining up the boomerang bracket. Drill two holes using a 3/8" drill bit and attach with the appropriate 3/8 bolt, washer, lock washer and nut.

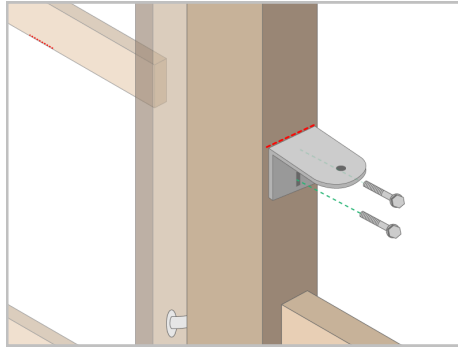

5. Place the trimmed boomerang bracket on top of the L shape bracket mounted in step 4. Then place firmly atop the boomerang bracket the second L shape bracket. Mount the second L shape bracket using 3/8" holes and hardware. After mounting of the second L shape, pivot the sandwiched boomerang bracket to match the setback and drill the boomerang bracket through hole of the L shape using a 3/8" drill bit.

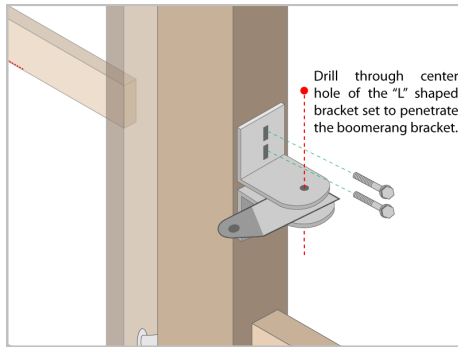

6. Insert the 3/8" bolt and secure the boomerang in place after checking once again it is positioned to match the setback using a lock washer, washer, and nut. Locate a part of the L shape brackets that when drilled through will also pass through the boomerang bracket. Drill using a 5/16" bit and secure using the 5/16" bolt, lock washer, washer and nut.

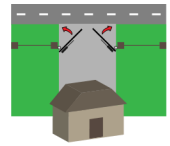
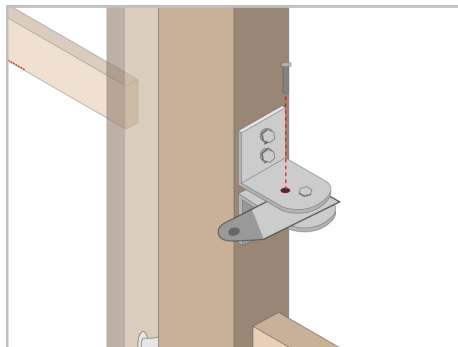

4. Place one of the L shape brackets with the top lined up with the line drawn on the post in step 3. The side of post the bracket will be on was determined in step 2 when lining up the boomerang bracket. Drill two holes using a 3/8" drill bit and attach with the appropriate 3/8 bolt, washer, lock washer and nut.

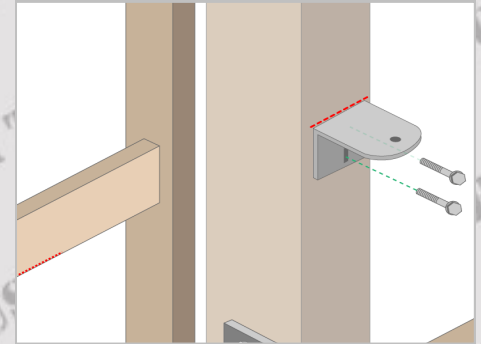

5. Place the trimmed boomerang bracket on top of the L shape bracket mounted in step 4. Then place firmly atop the boomerang bracket the second L shape bracket. Mount the second L shape bracket using 3/8" holes and hardware. After mounting of the second L shape, pivot the sandwiched boomerang bracket to match the setback and drill the boomerang bracket through hole of the L shape using a 3/8" drill bit.

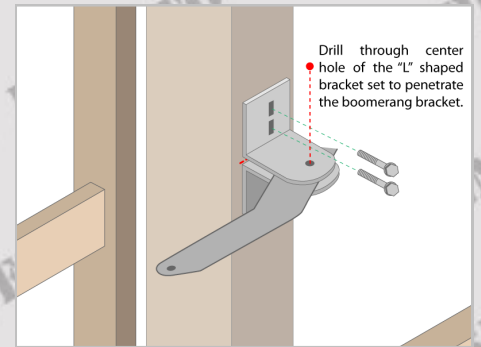

6. Insert the 3/8" bolt and secure the boomerang in place after checking once again it is positioned to match the setback using a lock washer, washer, and nut. Locate a part of the L shape brackets that when drilled through will also pass through the boomerang bracket. Drill using a 5/16" bit and secure using the 5/16" bolt, lock washer, washer and nut.

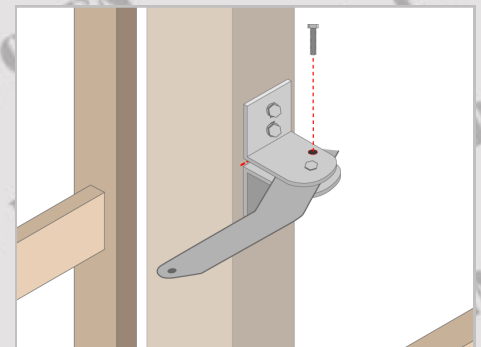

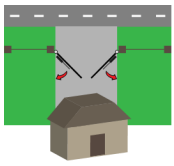

7. With the gate in the **OPEN** position, attach the gate opener to the post bracket assembly and gate bracket. Swing the arm over to the gate and mark the holes. For the gate bracket.

NEVER turn the shaft of the gate opener, it is located in the correct open retracted position from factory.

8. Prior to drilling the holes for your gate bracket, place a level on the shaft of the gate opener to check levelness.

Drill the two oblong holes with a 3/8" drill bit and secure using 3/8" carriage bolts, lock washers, washers and nuts. Recheck the open position, at this point it is adjustable by the length of the oblong holes. After the location is confirmed drill a 1/4" hole through the center hole of the gate bracket to lock its horizontal position. Secure with a 1/4" hex bolt, lock washer, washer, and nut.

9. Secure the arm in place with a cotter pin on the gate side and a C clip on the post side.

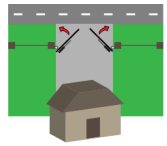
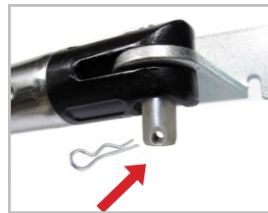
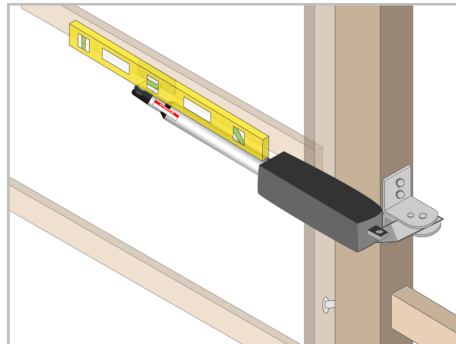
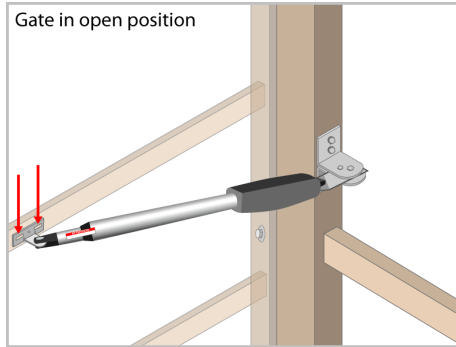

7. With the gate in the **CLOSED** position, attach the gate opener to the post bracket assembly and gate bracket. Swing the arm over to the gate and mark the holes. For the gate bracket.

NEVER turn the shaft of the gate opener, it is located in the correct closed retracted position from factory.

8. Prior to drilling the holes for your gate bracket, place a level on the shaft of the gate opener to check levelness.

Drill the two oblong holes with a 3/8" drill bit and secure using 3/8" carriage bolts, lock washers, washers and nuts. Recheck the open position, at this point it is adjustable by the length of the oblong holes. After the location is confirmed drill a 1/4" hole through the center hole of the gate bracket to lock its horizontal position. Secure with a 1/4" hex bolt, lock washer, washer, and nut.

9. Secure the arm in place with a cotter pin on the gate side and a C clip on the post side.

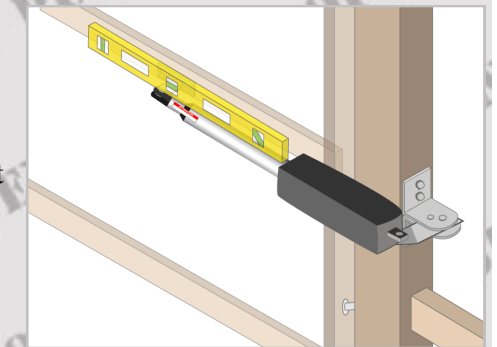
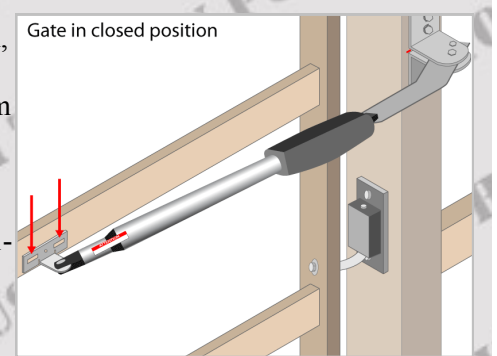

Mount the control box and run wires from the gate opener(s) into the box

10. Find a location for the control box within 5 feet of the operator arm (or primary operator arm for a dual gate opener) and at least 3 feet from ground level. Level the box on the post, column or fence and mount using 4) #10 self drilling screws or other hardware appropriate for the surface the control box is being mounted to.

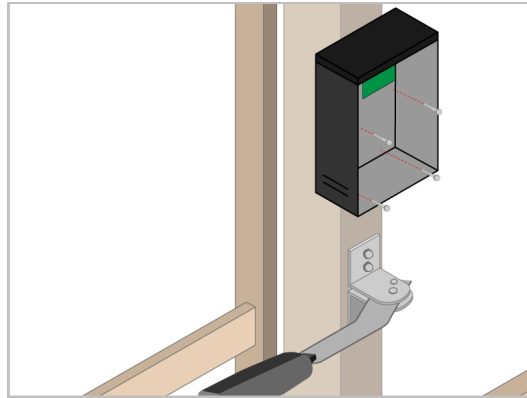

11. The box has 2) 1-1/4" and 4) 7/8" knockouts in the bottom. Remove the needed knockouts using a screwdriver and pliers. Push the screwdriver through an edge, grab and twist using the pliers. Insert a water tight connector. Run the wire from the gate operator through the connector to the location of the control board.

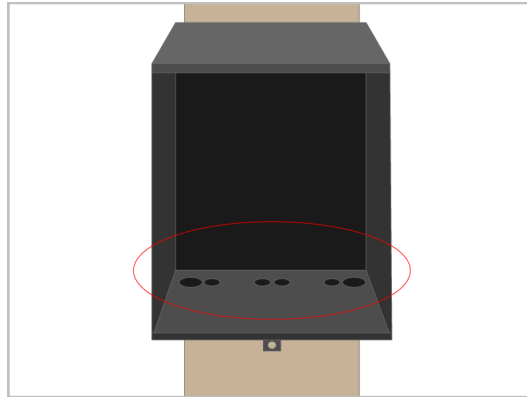

Connections for a dual gate

Mount the dual connection box on the secondary side of the gate on the post. Feed the secondary wire into the box and the secondary motor wire into the box. Place the connector strip in the box and match color to color on the connection strip.

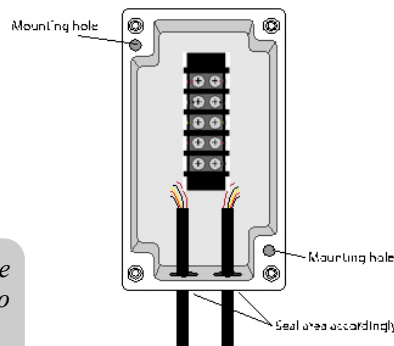

TIP: If junction box is located in a high moisture area, apply petroleum jelly on to the terminal block to protect from moisture.

Running wire under the driveway

Needed:

- Narrow shovel.
- 3/4" water pipe no more than 5' in length (you would need a total number of pipes that would equal your driveway width plus 1').
- 3/4" electric rigid pipe couplings (one for each joint in the water pipe).
- 1 3/4" "Tee"
- 1 3/4" Plug.
- 1 3/4" male galvanized pipe X female hose fitting (usually in Brass).
- Large hammer.

All the above items could be found in a local home supply store.

Dig a trench perpendicular to the driveway approximately 6 to 8 inches deep and 6' long

Hook up a typical garden hose assembled to the first length of pipe as shown



Turn on water and push the pipe under the driveway, matching the pitch of the driveway. If you hit a rock use the hammer to force the pipe past the rock.

Attach additional pieces of pipe to the initial length by removing the tee and using the coupling to add the additional length of pipe, reassemble the tee and repeat the above steps until only 6 inches of pipe is sticking out from under the driveway. On the opposite side of the driveway look for a wet spot or water bubbling up, dig to find the end of the pipe.

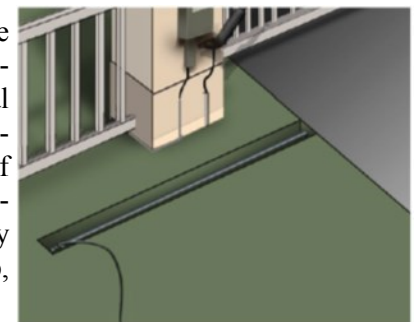

This process is good for driveways up to 24' in width.

Wire the Operator Arm(s) to the Control Board

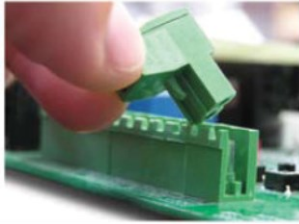

The green terminal strips on the control board are easily removed for wiring. Simply pull straight out on the terminal strip to remove it from the board. It will slide right off. Slide it back on when you are finished with your wiring connections.

Single Gate

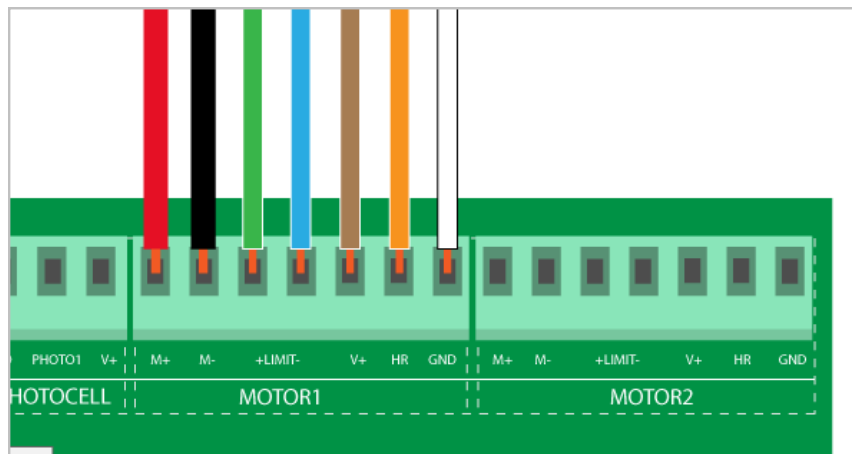

12. Connect the wires from the operator arm to the control board as seen above.

Dual Gate

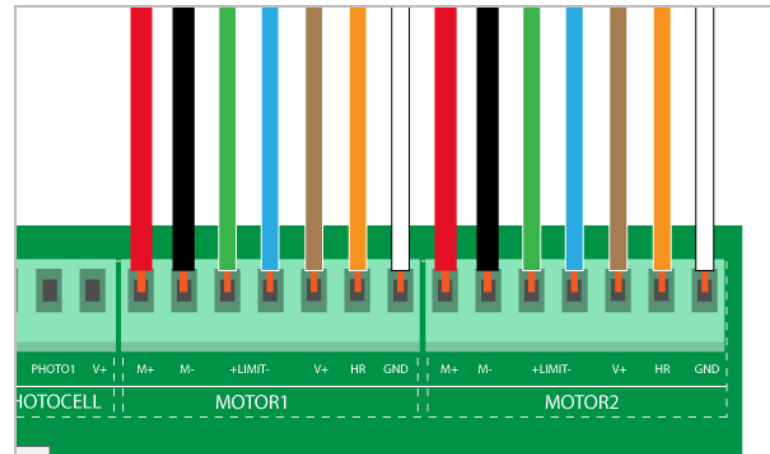

12. Connect the wires from the operator arms to the control board as seen above.

13. If not using a photo eye leave the factory installed jumper between the terminals PHOTO and GND installed. If using a photo eye it is best to leave the jumper installed until after programming is finished and accessories are being installed.

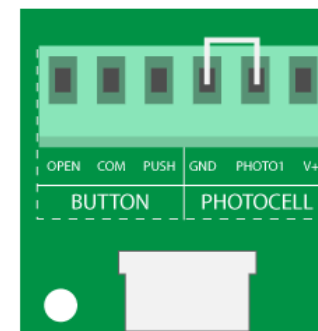

14. Set dip switches into the correct position for your gate opener:

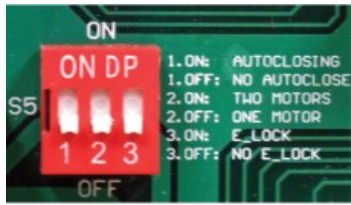

DP 1

ON: Auto-Close on (the gate will re-close from the open position after a time set in the programming section)
OFF: Auto-Close off

DP 2

ON: Dual gate opener (2 motors)
OFF: Single gate opener (1 motor)

DP 3

ON: Gate lock terminals active
OFF: Gate lock terminals inactive

Power Connection

15. Crimp the battery connectors (not included) to the battery wire. The only power connected to the Estate Swing E-S Allegiant control board will be the battery* (not included). **Important:** Please respect polarity when attaching the battery terminals. Do not cross wires. Connect the factory installed spade connectors to the control board as seen in diagram below.

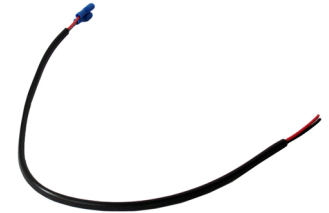

*A Group Size 24 Deep Cycle Marine battery is required for this system. The battery size may be increased for power storage. *Note: Deep cycle marine batteries are available at auto part stores, home stores, and battery stores.* If the battery sitting in the bottom of the control box no longer leaves room for wires to be fed into the box, set the battery atop the battery lifts.

16. Connect the charging controls to the battery. See below for connection details

Transformer / Charge board:

Transformer can be located up to 200 feet from the battery using 16 gauge 2 conductor wire. Connect positive and negative of transformer to positive and negative of solar terminals of charge board. Connect positive and negative of battery to positive and negative battery terminals of charge board. Respect polarity. Out terminals are not used. Charge board can be placed on top of battery. Transformer must be in an indoor location or under a plug cover.

20 Watt or Higher / Charge board:

Connect positive and negative of solar panel to positive and negative of solar terminals of charge board. Connect positive and negative of battery to positive and negative battery terminals of charge board. Respect polarity. Out terminals are not used. Charge board can be placed on top of battery.

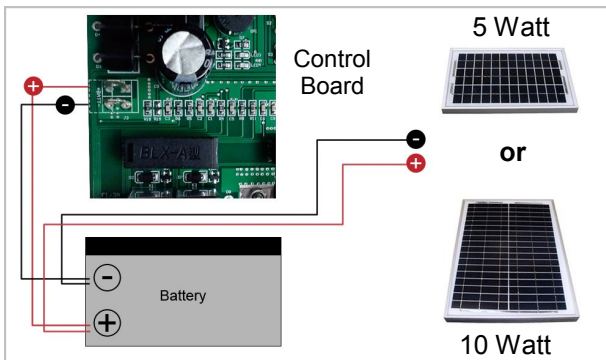
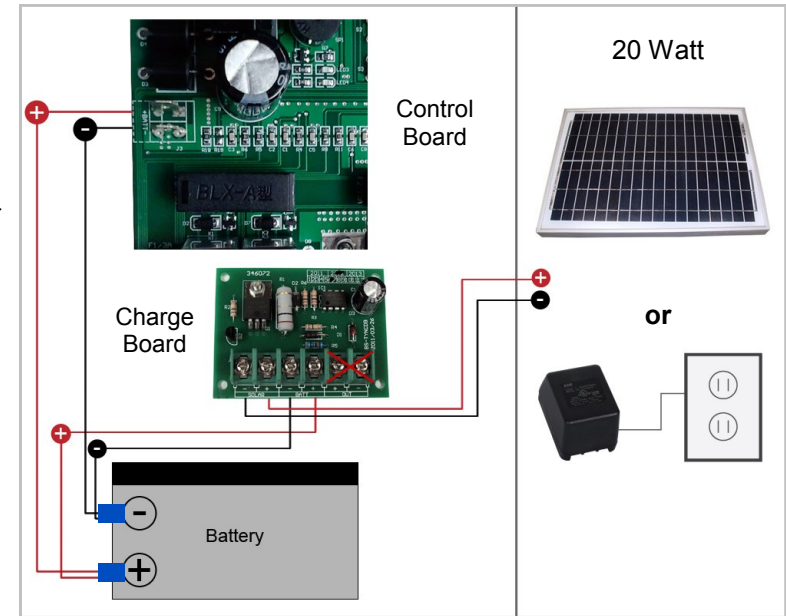

5 and 10 Watt solar panel

Connect the positive and negative of the solar panel directly to the battery respecting polarity.

Solar panels can be placed up to 200 feet away using 16 gauge 2 conductor wire. Solar panels must be in full sun and directed south.

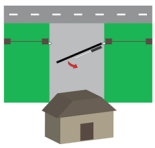

Programming Piston Extended Position

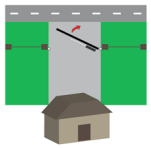

For SINGLE GATE Pull to Open:

17. Remove sticker on end of the arm. Press/release the SET button. P1 will show on the display. Press/release DEC button until 01 is on the display.

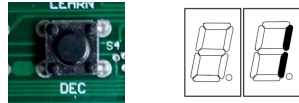
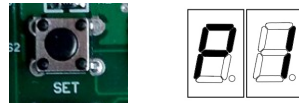

18. Press/release the SET button repeatedly until display returns to dots.

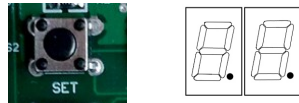

19. Press/hold the SET button until U1 is on the display.

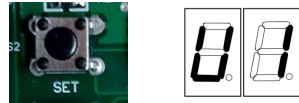

20. The gate opener is in programming mode. Press/hold DEC button. The piston will slowly extend as you hold DEC button.

Release the DEC button when the gate reaches the closed position.

If DEC button is released it can be pressed again to close further. If gate is over closed press/hold ADD button to retract piston.

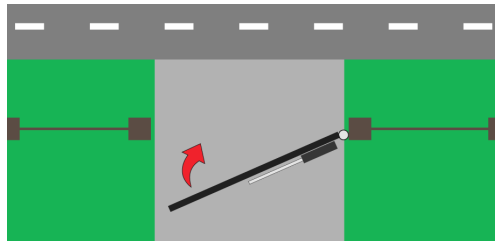

21. When closed position is correct press/release the set button. Then press/release ADD button.



The gate will slowly open to the full open position. Once open it will automatically close at full speed. Once closed, the programming is complete.

For SINGLE GATE Push to Open:

17. Remove sticker on end of the arm. Press/release the SET button. P1 will show on the display. Press/release DEC button until 00 is on the display.



18. Press/release the SET button repeatedly until display returns to dots.

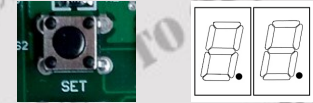

19. Press/hold the SET button until U1 is on the display.



20. The gate opener is in programming mode. Press/hold DEC button. The piston will slowly extend as you hold DEC button.

Release the DEC button when the gate reaches the open position.

If DEC button is released it can be pressed again to open further. If gate is past open press/hold ADD button to retract piston.

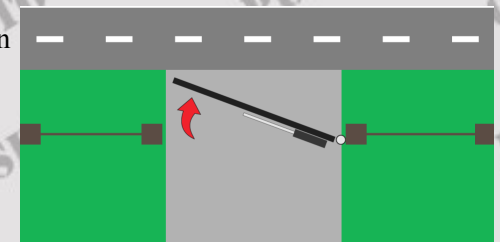

21. When open position is correct press/release the set button. Then press/release ADD button.



The gate will slowly open to the full closed position. Once closed it will automatically open at full speed. Once open, the programming is complete.

*Note: If reprogramming rather than programming for the first time read programming note in trouble shooting section first.

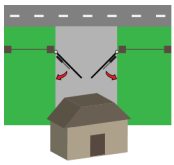

Programming Piston Extended Position

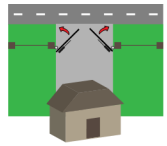

For DUAL GATE Pull to Open:

17. Remove sticker on end of the arm. Press/release the SET button. P1 will show on the display. Press/release DEC button until 01 is on the display.

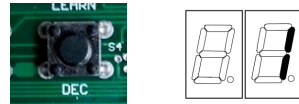
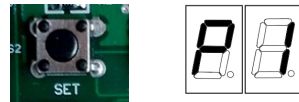

18. Press/release the SET button repeatedly until display returns to dots.

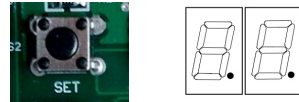

19. Press/hold the SET button until U1 is on the display.

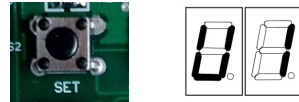

20. The gate opener is in programming mode. Press/hold DEC button. The secondary piston will slowly extend as you hold DEC button.

Release the DEC button when the gate reaches the closed position. If DEC button is released it can be pressed again to close further. If gate is over closed press/hold ADD button to retract piston.

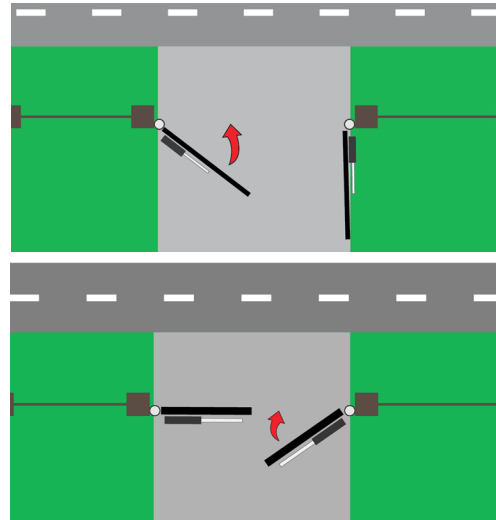

Press/release SET button and U2 will show on display. Repeat step 20 and secondary piston will close

21. When closed position is correct press/release the set button. Then press/release ADD button.

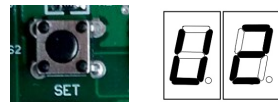

The gates will slowly open to the full open position. Once open it will automatically close at full speed. Once closed, the

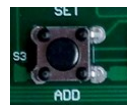

For DUAL GATE Push to Open:

17. Remove sticker on end of the arm. Press/release the SET button. P1 will show on the display. Press/release DEC button until 01 is on the display.

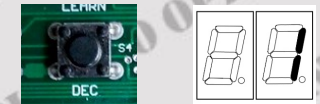

18. Press/release the SET button repeatedly until display returns to dots.

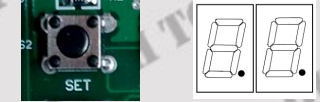

19. Press/hold the SET button until U1 is on the display.



20. The gate opener is in programming mode. Press/hold DEC button. The secondary piston will slowly extend as you hold DEC button.

Release the DEC button when the gate reaches the open position. If DEC button is released it can be pressed again to open further. If gate is past open press/hold ADD button to retract piston.

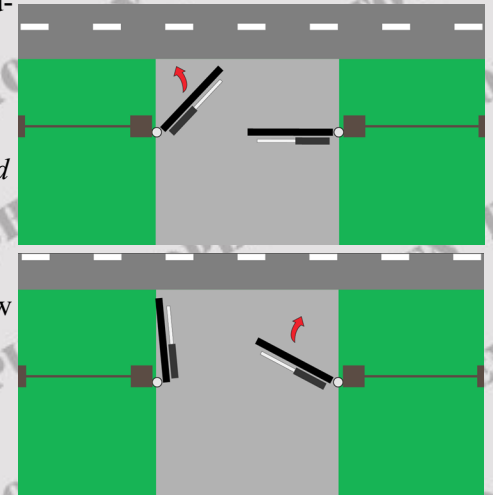

Press/release SET button and U2 will show on display. Repeat step 20 and secondary piston will close

21. When open position is correct press/release the set button. Then press/release ADD button.



The gates will slowly close to the full open position. Once closed it will automatically open at full speed. Once open, the programming is complete.



*Note: If reprogramming rather than programming for the first time read programming note in trouble shooting section first.

22. Set the parameters to match the needed settings. Press/release the SET button to access the parameters. Press/release the ADD or DEC buttons to review or change the individual parameter settings. Press/release the SET button to move to the next parameter.

P1 is setting pull or push to open.

00 = Push to open, 01 = Pull to open

P2 is setting primary leaf force. The lower the number the easier the gate will reverse directions when it meets resistance. This number may have to be changed to a higher setting if your gate is obstructing unexpectedly. The number should be set to the highest number during initial setup and reduced to the point of reliable operation that takes into account change in gate resistance through out the year. The options are 0-32.

P3 is setting secondary leaf force. *Note: this parameter will only show if Dip Switch 2 is UP.* The lower the number the easier the gate will reverse directions when it meets resistance. This number may have to be changed to a higher setting if your gate is obstructing unexpectedly. The number should be set to the highest number during initial setup and reduced to the point of reliable operation that takes into account change in gate resistance through out the year. The options are 0-32.

P4 is setting a delay between leafs if you have overlapping gates or a gate lock. *Note: this parameter will only display if DIP Switch 2 is UP.* The motor wired into the primary terminals (1) open first if there is a delay and closes second. It is recommended to have a delay of 3 seconds to avoid any jamming issues between leafs.

P5 is release time for the gate lock. *Note: this parameter will only display if DIP Switch 3 is UP and professional board is installed.* This option determines the length of time 12VDC will be sent out of terminals E_LOCK. The options are 1-4 seconds.

P6 is delay for automatic re-close from the open position. *Note: this parameter will only display if DIP Switch 1 is UP.* This option needs to be turned on using the dip switch on the board. The options are 0-99 seconds.

23. Program remote transmitters to the board. Press/release the learn button. Learn LED will illuminate.

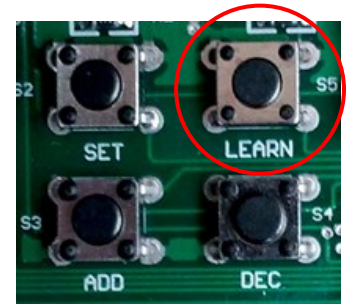

24. Press/hold a button on a remote transmitter until the learn LED flashes.

Repeat step 24 with other buttons on the remote or buttons on other remotes.



NOTES ABOUT REMOTES:

You can program up to 400 codes into the receiver. This could mean 1 button on 400 different remotes or this could mean all 4 buttons on 100 remotes or anything in between. Some choose to program all 4 buttons to a single receiver if they are not using multiple gates to eliminate pressing the incorrect button on the remote. To do so follow the programming above with each button of the remote. You can erase all programmed codes by holding Learn 1 until the Learn LED comes ON and then turns OFF.

25. The gate opener is now installed and operational via remote transmitter. Please review the troubleshooting / control board overview section following this page for more information on your gate opener. Also review this area for more information on optional accessory installation.

*Thank you sincerely for your trust in
Estate Swing products!*